

Triumph Pools Installation Instructions

Introduction

The Triumph pool is designed to be suitable for installation above ground, partially in ground, or completely in ground. It is recommended that Oval shaped pools are installed a minimum of 30" in the ground.

Please read through these instructions thoroughly before attempting to begin installation.

Check to ensure that the required services (water, electrical, etc.) are sufficient to run your pool equipment. Have locates to ensure telephone, hydro, gas, cable, septic and any other underground utilities are not in the excavated area.

Ensure that you have obtained a proper building permit and be aware of local regulations concerning fence height, shape and size.

Available Shapes and Sizes

Round:	12'	15'	18'	20'	24'	27'	30'
Oval:	12' x 16'	12' x 20'	12' x 23'	12' x 27'			
	15' x 23'	15' x 27'	15' x 30'				
	18' x 25'	18' x 29'	18' x 33'	18' x 33'			
	20' x 28'	20' x 32'	20' x 36'	20' x 40'			

Prerequisites

While selecting the pool site, choose an open, sunny area. Again, be aware of any underground utility lines. The pool should be in an area where the surface water tends to drain away from the pool.

Try to locate the pool in a place that will allow for short, easy plumbing work.

Material Required

- Compaction sand
- Stone dust
- Concrete pavers (approximately 1 for every 4' of perimeter)

Bottom Mix

Two types of pool bottoms can be installed:

- Sand bottom - using compacted sand
- Hard bottom - using hard mix available from ready-mix companies or building supplies

Pool Layout

For round pools, stake out an area 2' larger than the pool diameter (*see figure1*).

For oval pools, stake out an area 4' wider than the pool width, and 2' longer than to pool length, such that there is a 1' trench around the curved ends of the pool, and a 2' trench along the straight sides (*see figure2*).

Mark these areas using chalk or spray paint.

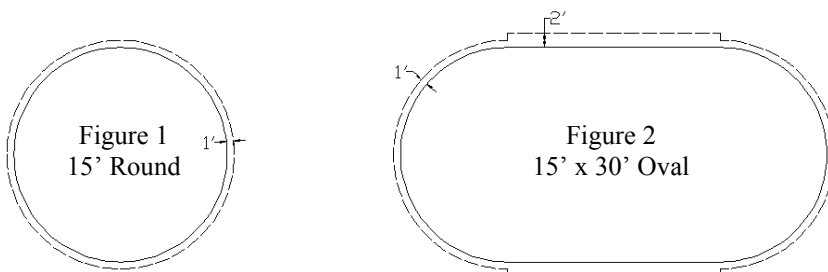

Excavation

The pool bottom should be excavated 2" to 3" deeper than the finished pool depth to allow room for the bottom material.

Preparing the Site

Trace the pool perimeter and cover the collar with stone dust 3" thick and 12" wide. Insert a concrete slab at every panel joint and at the center of each panel over 4' long. (see figure 3)

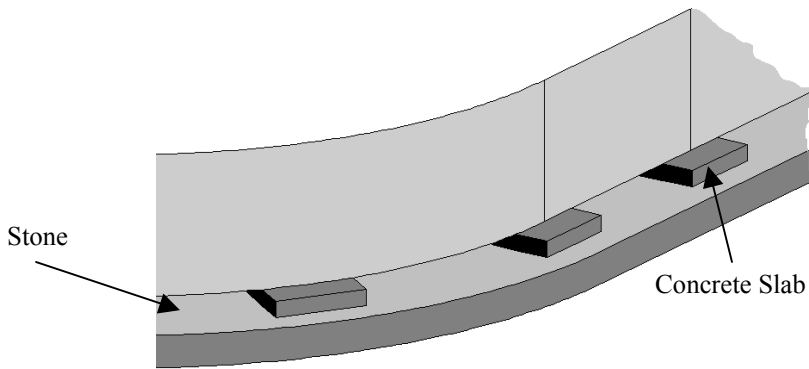

Figure 3

Panel Installation

After bolting the panels together, square and level the pool walls, checking the dimensions to the installation drawing.

Ensure all the nuts and bolts are well tightened. A-frame assemblies are required for oval pools. The A-Frames must attach to the pool sides (see figure 4).

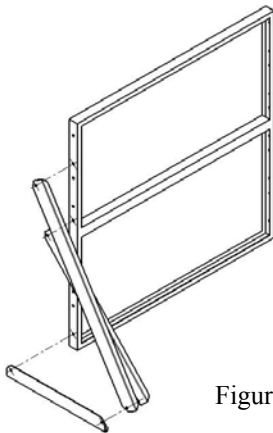

Figure 4

For ovals installed above ground, poured concrete (formed by concrete forming tubes) is recommended for anchoring the A-frames to the ground (see figure 5).

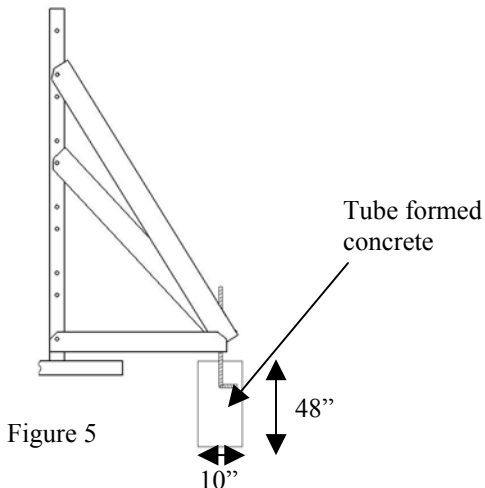

Figure 5

For ovals installed in the ground, the A-frames can be cemented in by enveloping the bottom of the frame in poured concrete.

Steps

Steps are to be installed a minimum of 36" in ground to ensure solidity. If the step is installed incorrectly, no warranty will be honored on the step, or the triumph pool.

Skimmer Installation

Depending on the installation, each pool kit will come with a skimmer, and one panel pre cut to accommodate the skimmer. For installation, refer to the instructions provided by the skimmer's manufacturer.

Return Fitting Installation

Each pool kit comes with one or two return fittings and the same number of pre cut panels to accommodate them. Refer to the instructions supplied by the skimmer manufacturer for installation.

Main Drain Installation

Each pool kit comes with two main drains. The main drains must be teed together a minimum distance of 3' apart, and connected directly to the pump. Concrete pads approximately 4' x 2' can be poured to hold the main drains in place.

Pipe / Fitting / Filter Installation

The use of flexible PVC piping is recommended for the pool circulation network. Rigid PVC piping may be used in regions where frost conditions do not exist.

Piping should slope uniformly in one direction with no kinks or dips (to avoid possible air locks). Ensure piping does not come into contact with sharp edges such as A-frames.

Connect the skimmer and the main drain to the filter pump.

Connect the return fittings to the return outlet of the filter tank. In cases where there is more than one return, a tee can be used to connect a both returns to a single return line.

Pressure-test all lines to ensure there are no leaks.

WARNING: Do not use pipe dope on fittings. Use only silicone or Teflon tape.

Backfilling the Pool

If the pool is to be installed in ground or partially in ground, it is recommend that a land drain be installed to eliminate any excess water in the ground. At this stage, the pool can be backfilled, though backfilling can be postponed until after the liner is installed. When backfilling, ensure that the backfill is sloped away from the pool.

Pool Bottom Preparation

Once the excavated hole is dry (no longer needs continuous pumping to drain the water off), sand or hard mix can be applied on the firm earth approximately 2"-3" thick. For sand bottom pools, it is recommended that a geo textile fabric be placed under the sand mix to prevent rocks from working up through the sand into the liner.

Coping Installation

The coping comes in 8' lengths. Screw the coping in place using self tapping screws.

Fasten the aluminum coping to the face of the panel, placing screws every 6", with the top of the track 1/2" higher than the top of the wall.

Snap the PVC top cap over the top rail of the pool, screwing the backside of the PVC to the top rail of the pool wall.

The outside of the PVC top cap has a receptacle which can accept vinyl siding, cedar, pressure treated fence boards, or most any other material to decorate the outside of the pool. See figure 6.

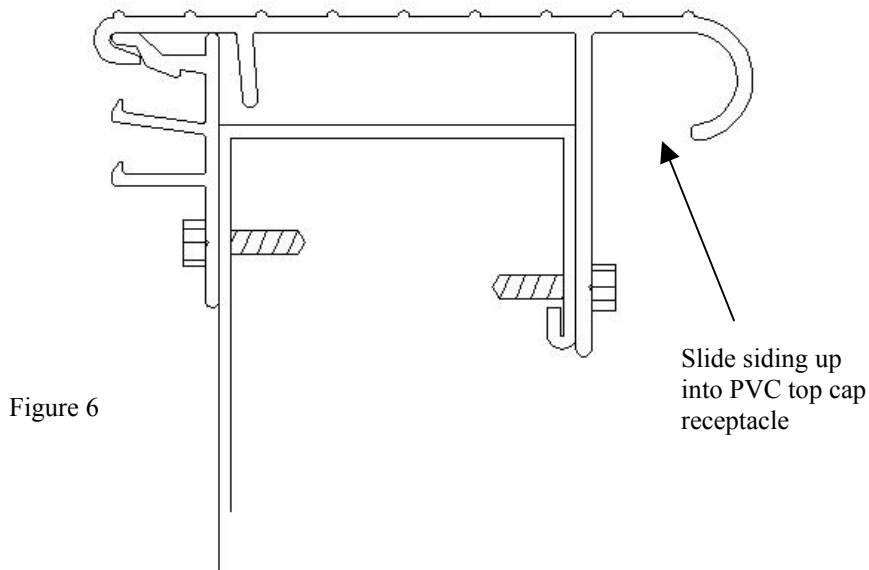

Figure 6

Installing the Liner

Liners are best installed in warm weather to allow for easier stretch in the vinyl and to make packaging wrinkles disappear easier. If installing a liner in cool weather, prior to installation, allow it to warm up in a heated room for a day or two.

Step 1

Double check the pool bottom, ensuring that there are no sharp stones or objects that might damage the liner. Ensure the steel walls are dry and cleaned of any cement that may have splashed on them.

Step 2

At this point, the main drain, skimmer, and return gaskets must be put in place. See the respective installation instructions for each.

Step 3

Tape all the panel joints in the pool with duct tape. The inside lip of the coping may also be taped to improve the vacuum suction when vacuuming the air out from behind the liner.

Step 4

Take the liner out of the box. Lift the liner over the pool wall so the floor of the liner is inside the pool (being mindful of any objects or obstacles on the ground).

Step 5

While keeping hold of the liner wall, walk around the perimeter of the pool until the liner is oriented correctly (this is not applicable to round pools installed above ground). Two people are required to install the liner, but four are recommended.

Step 6

Insert the liner bead into the coping track. Any final adjustment to the liner orientation should be made now.

Step 7

Insert a vacuum (shop or industrial strength) hose through the skimmer and behind the liner about 18”.

Step 8

Seal the top of the skimmer and around the vacuum hose with tape. Also ensure all plumbing lines from the skimmer and returns are also sealed with tape.

Step 9

Plug the vacuum into a GFI (ground fault interrupt) receptacle. Start the vacuum.

The liner will draw against the pool walls and floor. If liner appears to need repositioning or adjustment, it may be necessary to stop the vacuum to do so.

NOTE: If wrinkles persist, or the liner does not fit properly, DO NOT add water or cut any fittings. The addition of water will not remove wrinkles or folds.

WARNING: Wear stocking feet while walking on the liner, and take care not to drop any tools on the liner.

Step 10

Once the liner is in place, begin filling the pool (leaving the vacuum running). Once 6" to 8" of water has accumulated, install the main drain face flanges (see manufacturer's instructions).

Cut out the liner along the inside edge of the face flanges, and install the covers. Install the covers and fasten with the screws supplied with the drains.

Step 11

Once the water level has reached 4" below the vacuum hose, the vacuum can be turned off and removed.

Step 12

Once the water level reaches the return fitting(s), install the face plates (see manufacturer's instructions)

Step 13

Install the skimmer face flange as per the manufacturer's instructions