

① Install top mount coping to top of pool panel

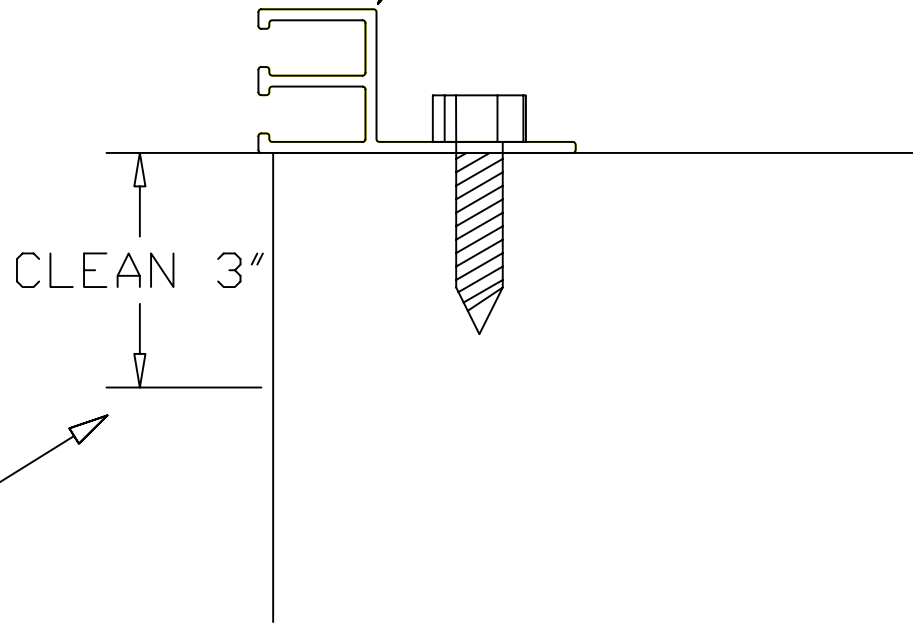

② Clean top 3" of panel faces to ensure *ProFORM* adhesive will adhere.

*For straight panels proceed to step #4

- ③ Use fillament tape on concave radii (reverse panels) to strengthen the foam, and prevent cracking.

Attach several strips of tape on the backside of the *ProFORM* / *ProSTONE* foam. This will allow the foam to be formed around the desired radius.

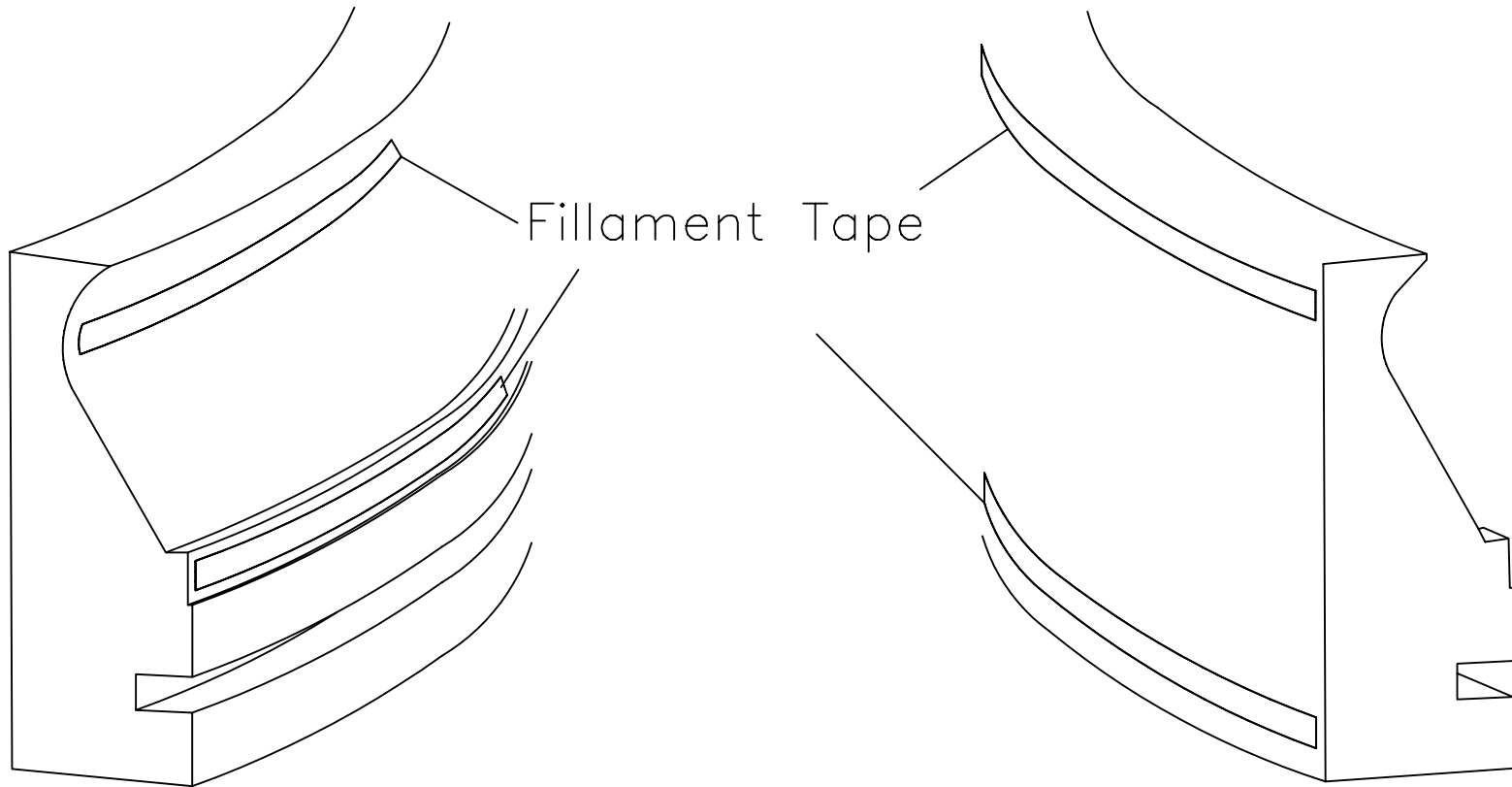

④ Remove the backing from the adhesive tape on the front of the *ProFORM* / *ProSTONE*

⑤ Line up the bottom of the profile to the top of the coping and press on firmly.

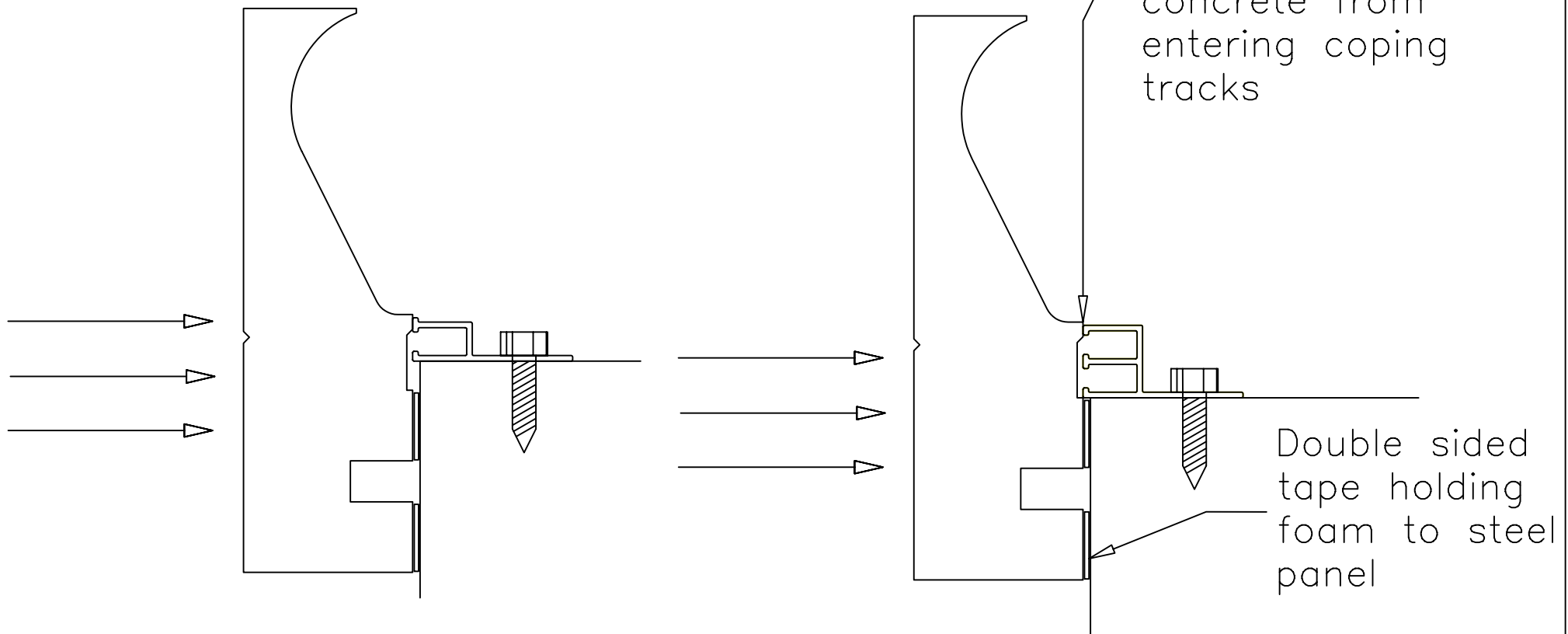

- 6 Holding the *ProLOCK* at 90° to the *ProFORM* / *ProSTONE*, gently pierce the Pro Lock through the foam using the indented guide line as a reference through the foam to the coping (If using dual track coping, *ProLOCK* should line up with top track).

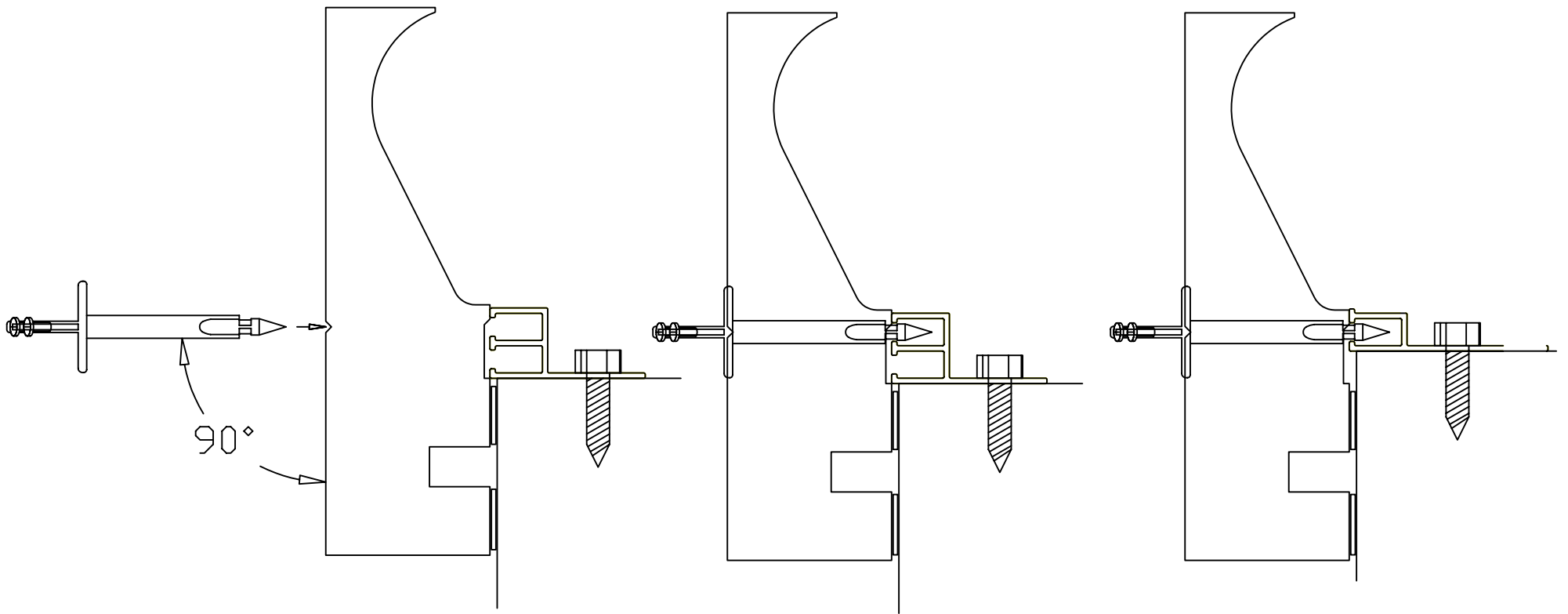

- 7 Turn *ProLOCK* one quarter turn as required such that it is vertically oriented (as depicted below), to lock it in place.

