

MISCELLANEOUS INFORMATION

PERIMETER:	98'7"
SURFACE AREA:	623 SQ FT
VOLUME:	19997 IMP GALS 90986 LITER

CONCRETE DECK INFO

WIDTH	AREA	NET INCREASES FOR:			
		STEPS	DIVING	SLIDE	ROLLER
2'	210	13	27	24	10
2'6"	0	17	31	20	10
3'	0	20	36	16	10

All Figures Represent "Sq Ft"

PARTS LIST

CODE	QTY	DESCRIPTION
4R8	1	4' Plain x 8' Radius
8-s	1	8' Skimmer
7	2	7' Plain
2RC	2	3'2" Plain x 2' Rad Cnr
17R2R	1	1'7" Plain x 2' Reverse Radius
5R8R	1	5' Plain x 8' Reverse Radius
8	1	8' Plain
1	1	1' Plain
17R2	3	1'7" Plain x 2' Radius
3R24	1	3' Plain x 24' Radius
8R24-i	2	8' Return x 24' Radius
8R24	2	8' Plain x 24' Radius
6R24	1	6' Plain x 24' Radius
5	1	5' Plain
AF	20	A-Frame
S	40	Stakes
NB	120	Nuts & Bolts

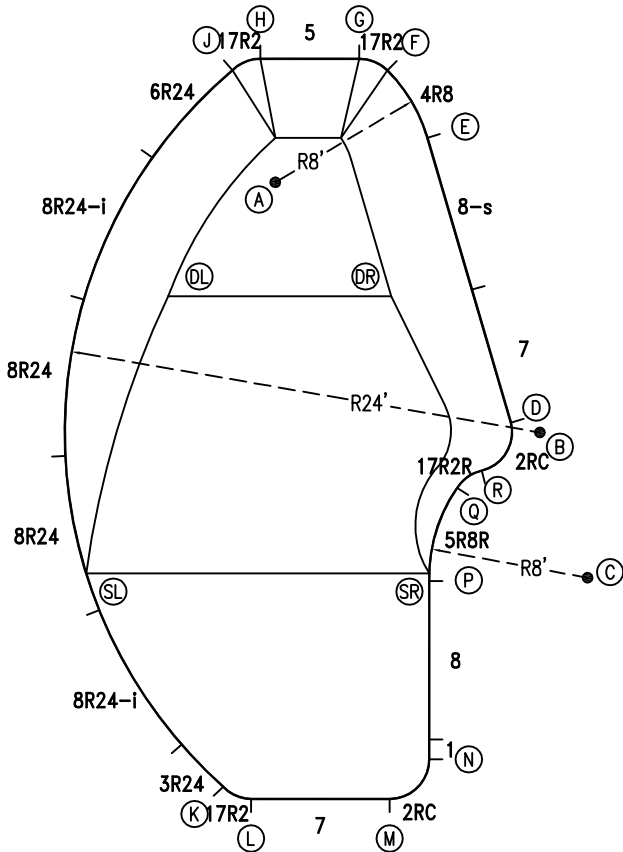

6" WATER LINE

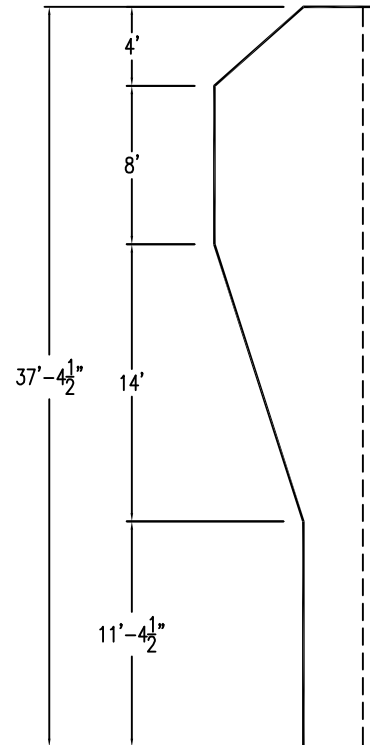

INSTALLATION DATA

From Point "A" to:-		From Point "B" to:-	
B	18'-4 3/4"	B	7'-8 1/2"
C	25'-5 1/4"	C	1'-6 1/2"
D	17'-0"	D	1'-6 1/2"
E	8'-0"	E	15'-11 1/4"
F	8'-0"	F	19'-10 1/4"
G	7'-6 1/2"	G	20'-11 1/2"
H	6'-3 1/2"	H	23'-6 3/4"
J	6'-0 3/4"	J	24'-0"
K	30'-7 3/4"	K	24'-0"
L	31'-2"	L	23'-6 3/4"
M	31'-8"	M	20'-0"
N	30'-2"	N	17'-5 1/4"
P	21'-7"	P	9'-4 1/4"
Q	17'-11 1/2"	Q	5'-0 1/4"
R	17'-10 3/4"	R	3'-6"
SL	21'-11 1/4"	SL	24'-0"
SR	21'-2 3/4"	SR	9'-0 1/2"
DL	7'-10 3/4"	DL	20'-0"
DR	8'-2 1/2"	DR	10'-2"

NOTICE

SWIMMING POOLS AND ACCESSORIES (INCLUDING DIVING BOARDS) ARE DANGEROUS WHEN IMPROPERLY USED OR INSTALLED. IT IS THE RESPONSIBILITY OF MUNICIPAL OFFICIALS, BUILDERS AND POOL OWNERS TO ADHERE TO ALL SAFETY RECOMMENDATIONS AND STANDARDS ISSUED BY THE POOL & HOT TUB COUNCIL, LOCAL AUTHORITIES AND EQUIPMENT MANUFACTURERS. PLEASE REFER TO DIVING BOARD MANUFACTURERS FOR CORRECT POSITIONING AND INSTALLATION OF DIVING EQUIPMENT.

*ALL DIMENSIONS ARE FINISHED

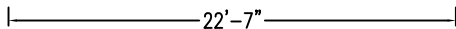
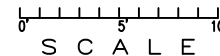

PERIMETER: 98'7"

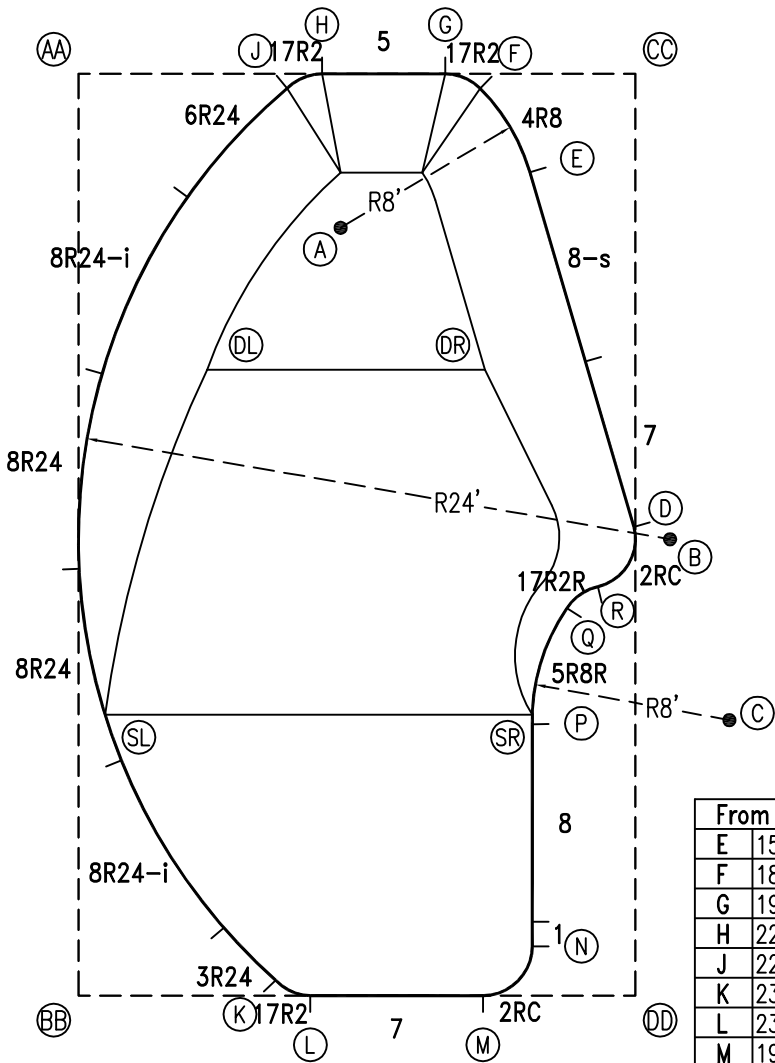

EXTERNAL INSTALLATION DATA

AA TO:	BB TO:	CC TO:	DD TO:
AA ---	AA 37'-4 3/4"	AA 22'-7"	AA 43'-8 1/4"
BB ---	BB ---	BB 43'-8 1/4"	BB 22'-7"
CC ---	CC ---	CC ---	CC 37'-4 3/4"
A 12'-4"	A 32'-10 3/4"	A 13'-5 3/4"	A 33'-4 1/4"
B 30'-6 1/2"	B 30'-3 3/4"	B 18'-11 1/4"	B 18'-6 3/4"
C 37'-2 1/2"	C 28'-8"	C 26'-5 3/4"	C 11'-9 3/4"
D 29'-1"	D 29'-5 3/4"	D 18'-4 1/2"	D 19'-0"
E 18'-8 3/4"	E 38'-1"	E 5'-10 1/4"	E 33'-8"
F 16'-3 1/2"	F 40'-3"	F 6'-3 3/4"	F 37'-4"
G 14'-10 1/2"	G 40'-2 3/4"	G 7'-8 1/2"	G 38'-2"
H 9'-10 1/2"	H 38'-8"	H 12'-8 1/2"	H 39'-5 3/4"
J 8'-5 3/4"	J 37'-9 1/4"	J 14'-1 3/4"	J 39'-5"
K 37'-7 1/2"	K 8'-0 1/4"	K 39'-6 3/4"	K 14'-7 1/4"
L 38'-6 3/4"	L 9'-4 3/4"	L 39'-7 3/4"	L 13'-2 1/4"
M 40'-10"	M 16'-4 3/4"	M 37'-10 3/4"	M 6'-2 1/4"
N 39'-10 3/4"	N 18'-6 1/4"	N 35'-7 1/2"	N 4'-7 1/2"
P 32'-2"	P 21'-5 1/4"	P 26'-8 1/2"	P 11'-9 1/4"
Q 29'-4 1/2"	Q 25'-3 1/2"	Q 21'-10 1/4"	Q 15'-11 1/2"
R 29'-7 1/4"	R 26'-9 3/4"	R 20'-10 1/4"	R 16'-7 3/4"
SL 26'-0 1/4"	SL 11'-5 1/4"	SL 33'-8 3/4"	SL 24'-4"
SR 31'-10 1/4"	SR 21'-7 3/4"	SR 26'-4"	SR 12'-1 1/2"
DL 13'-1"	DL 25'-11"	DL 21'-1 1/4"	DL 30'-9 1/4"
DR 20'-4 3/4"	DR 30'-3 1/4"	DR 13'-5 1/2"	DR 26'-1 1/4"

DIAGONALS

From Point "D" to:-	From Point "E" to:-
E 15'-0"	E
F 18'-10 3/8"	F 3'-11 1/2"
G 19'-10 7/8"	G 5'-3 1/8"
H 22'-3 7/8"	H 9'-3 7/8"
J 22'-8 1/4"	J 10'-5"
K 23'-5 1/4"	K 34'-4 3/8"
L 23'-1 1/4"	L 34'-6 7/8"
M 19'-11 5/8"	M 33'-5 1/2"
N 17'-6"	N 31'-4 7/8"
P 9'-0 1/8"	P 22'-4 7/8"
Q 4'-3 1/4"	Q 17'-9"
R 2'-9 7/8"	R 17'-0 1/2"

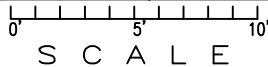

NOTICE

SWIMMING POOLS AND ACCESSORIES (INCLUDING DIVING BOARDS) ARE DANGEROUS WHEN IMPROPERLY USED OR INSTALLED. IT IS THE RESPONSIBILITY OF MUNICIPAL OFFICIALS, BUILDERS AND POOL OWNERS TO ADHERE TO ALL SAFETY RECOMMENDATIONS AND STANDARDS ISSUED BY THE POOL & HOT TUB COUNCIL, LOCAL AUTHORITIES AND EQUIPMENT MANUFACTURERS. PLEASE REFER TO DIVING BOARD MANUFACTURERS FOR CORRECT POSITIONING AND INSTALLATION OF DIVING EQUIPMENT.

HIGHBURY POOLS LTD

WASAGA - RIGHT 23 x 23 x 37

DRAWING REFERENCE #
94-23-37-2

DRAWN BY: JK
REV. 29 AUG 13
SHEET 2 OF 2